

Stadium Burger Chute ECO

VI017S



- All Stainless steel construction
- Simple ON/OFF switch operates the heat lamps
- Designed for front and rear loading and unloading
- Complete with lane listing strips and holders

STADIUM BURGER CHUTE ECO SPECIFICATION PAGE

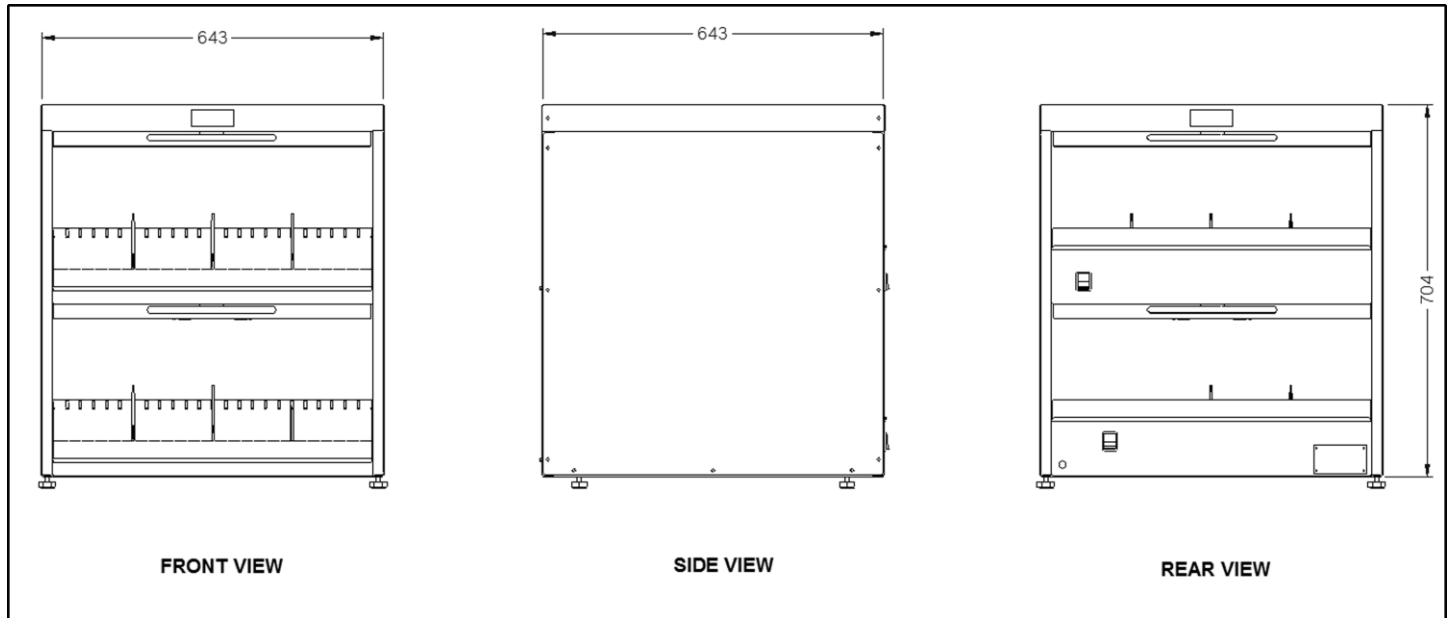

Model VI3TFC

Dimensions	Machine (MINI)
Height	705mm
Width	645mm
Depth	645mm
Weight	53kg
Electrical	1 phase, 50Hz AC, 230v, 1.425Kw
Running Amps	6.3 Amps
Connection Type	2m BESCHUKO Euro cable with, MFEUROCONVERT Euro to UK converter plug
International	N/A

All **Vizu Stadium Burger** have been tested and checked for proper operation before leaving the factory.

Upon delivery please check the unit for damage. If the unit is damaged, contact the carrier, or Fast Food Systems, immediately and file a damage claim (found in the back of the manual) Please retain all packing materials.

Damage must be reported within 7 days of delivery.

Assembly Instructions

1. Remove all packing from the unit.
2. Peel off all protective plastic covering from metal
3. Wash all removable parts in warm, soapy water and dry them thoroughly.
4. Place chutes into position, Note: 4 per tier.

Installation

Position the *Vizu Stadium Chute ECO* in desired position, close to a suitable electrical supply and connect.

Operating instructions

1. Switch the two red rocker switches 'ON' to operate the top and bottom lights and ceramic elements.
2. The top section can be switched off leaving only the lower section working.
3. Allow unit to heat up for 20 minutes.

Cleaning instructions



1. Disconnect the unit from its power supply.
2. Remove chutes and clean.
3. Clean all stainless steel surfaces with proprietary stainless steel cleaner, such as Sheila Shine and a soft lint free cloth.

Note: Do NOT use abrasive cleaners or pads and do NOT bleach.

4. Wipe ceramic elements only when they are cold with a damp clean cloth.
5. Do NOT touch or clean (quartz) heat lamps with fingers, as this will reduce the life of the tubes.
6. Dry all surfaces thoroughly removing all moisture.
7. Replace chutes and re-connect to power supply.

Spare Parts Listing

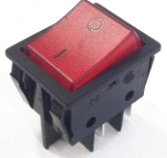
PART NO.	DESCRIPTION	QTY.	IMAGE
BESCHUKO	H05Rr-F 2Mtr. Rubber C032	1	
MF100WRJ	IRL 100JV 100W jacketed Ir quartz bulb	2	
BAVIZULABELS	MQ4658CR Vizu labels	2	
MF817-8877	Black Nylon 66, strain relief cable bush	1	
MF354Z	2 Pole 5amp term block TB06	6	
MFOHSL01	High temperature sleeving	1	
MF605-649	Grommet	3	
MFQUARTZJACKET 100W	Jacket Lamp Assembly 100W	2	
MFCOMMON1	Label 5 140mm x 53mm	1	
MFEUROCONVERT	Euro to UK converter plug In black 19-1032	1	
MFESC300W	Infra-red ceramic heaters (318-334)	4	
MFRT34AFM	Adjusted (feet) Rth34Afm0839 49537	4	

PART NO.	DESCRIPTION	QTY.	IMAGE
VILE14	Switch cover / bezel HD2/HD4 MFF1025 / MF1026	2	
VISW17	Rocker switch HD2 Revolva HD4 MFC1553ALR	2	
MF374-1029	10mm low profile lens indicator 230VAC	1	

Warning, when replacing bulbs

The lamps whilst being a high output unit are fragile. They must be handled with care and they must be kept clean. Guards are fitted to prevent dirt and grease contacting the bulbs. Grease from fingers will weaken the surface of the bulb this will lead to fracture and failure; bulbs should always be held using gloves or a wad of tissue to grip the bulb in.

Fault finder

Qualified personnel must carry out any servicing.
 Disconnect from power before servicing.

Problem	Possible cause	Solution
Indicated ON/OFF switches do not light up.	<ul style="list-style-type: none"> No power to machine. Both switches are faulty 	<ul style="list-style-type: none"> Check machine is plugged in and switched on. Check fuse in 13a plug top. Check circuit breaker at mains supply board is in i.e. ON. Replace switches.
2. Top indicated on/off switch does not illuminate	<ul style="list-style-type: none"> No power to switch Switch faulty 	<ul style="list-style-type: none"> Check machine is plugged in and switched on. Replace switch.
3. Bottom indicated on/off switch does not illuminate	<ul style="list-style-type: none"> No power to switch Switch faulty 	<ul style="list-style-type: none"> Check machine is plugged in and switched on. Replace switch
3.Heat lamps do not light	<ul style="list-style-type: none"> ON/OFF switch is in OFF position. Faulty ON/OFF switch. Heat lamp is faulty. 	<ul style="list-style-type: none"> Switch to ON. Replace switch. Replace switch. Replace lamps
5. Only one heat lamp lights.	<ul style="list-style-type: none"> Lamp is faulty. 	<ul style="list-style-type: none"> Replace lamp.
6.Ceramic heaters not operating.	<ul style="list-style-type: none"> Switch faulty Heater is faulty. 	<ul style="list-style-type: none"> Check switch, replace as necessary Replace heater.

VI017S STADIUM CHUTE ECO

EXPLODED VIEW

Item	File Name (no extension)	Rev	QTY	Sheet
1	16-14 - BASE	-	1	0.90 mm
2	16-15 - SHELF LWR	-	1	0.90 mm
3	16-16 - INNER SIDE	-	1	0.90 mm
4	16-16 - INNER SIDE_OPP	-	1	0.90 mm
5	16-17 - SHELF UNDERSIDE_A	-A	2	0.90 mm
6	16-18 - SHELF MID_A	-A	1	0.90 mm
7	16-19 - TOP	-	1	0.90 mm
8	16-20 - SIDE COVER	-	2	0.90 mm
10	16-08 FOOD CHUTE	-	2	0.90 mm
11	16-11 FOOD CHUTE DIVIDER	11	6	0.90 mm
12	16-21 - CHUTE SKIRT	-	2	0.90 mm
13	CERAMIC ELEMENT	-	4	
16	MFRT34AFM ADJUSTABLE FEET	-	4	
17	VISW17 + VILE14 - ROCKER SWITCH RED ASSY	-	2	
18	MF NE30 LIGHT RED	-	1	
19	SPRUNG LIGHT HOLDER	-	2	

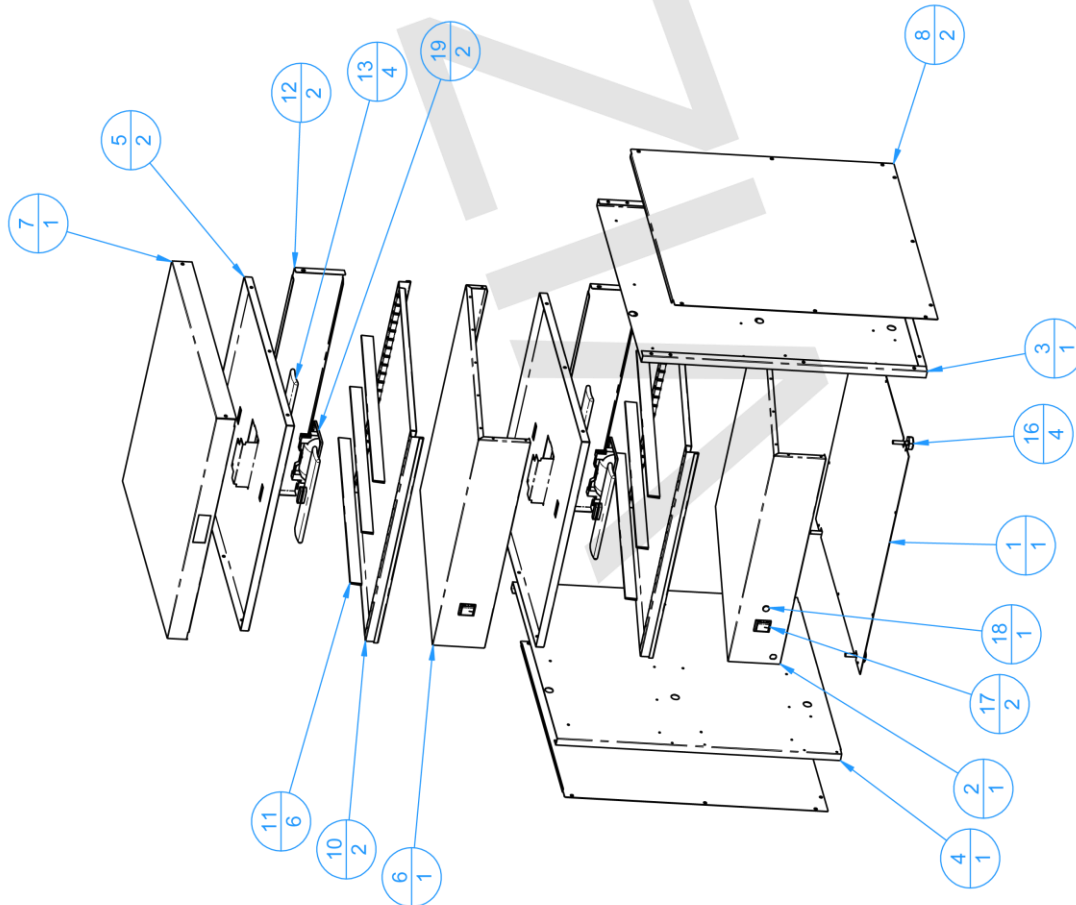

WIRING DIAGRAM

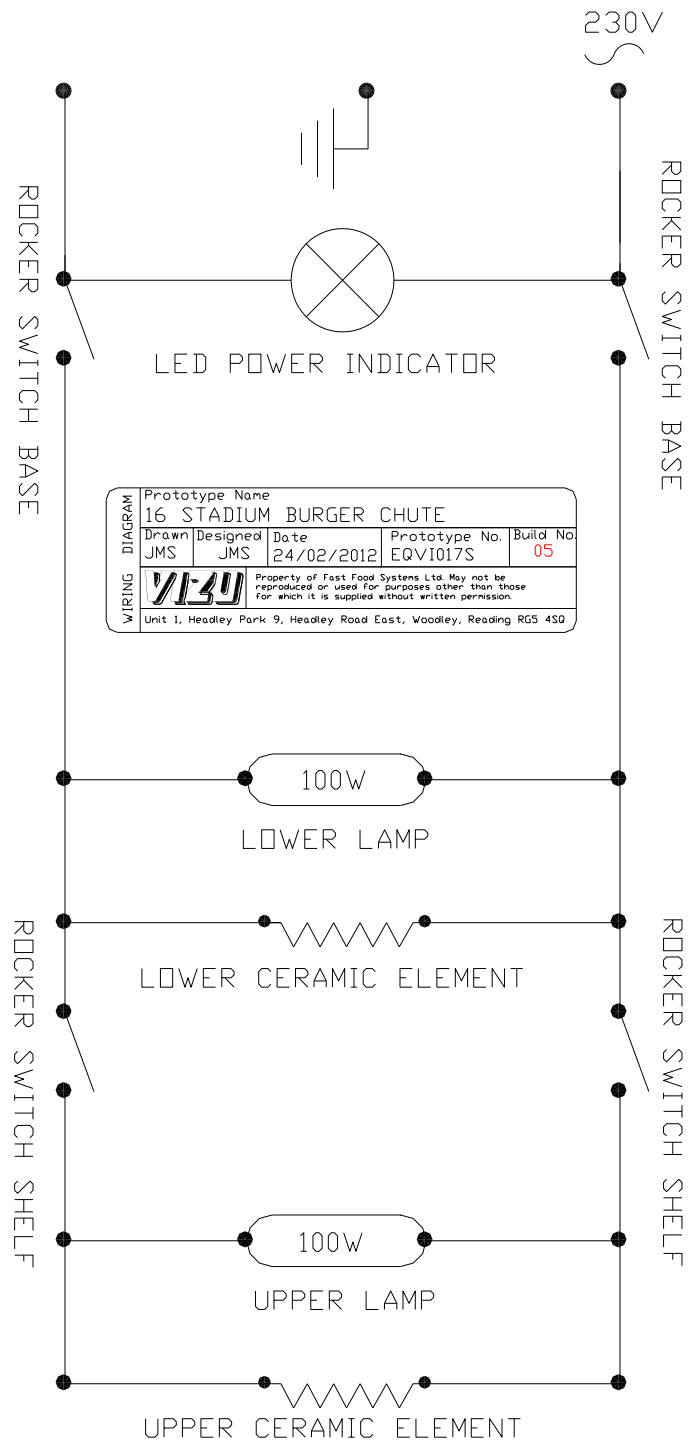

Terms and Conditions

Claims

No claim shall be entertained by the Company unless made in writing. Claims arising from damage or partial loss in transit must reach the Company within 7 days from the date of delivery. Claims for non-delivery must reach the Company within 10 days from the date of dispatch. All other claims must reach the Company within 7 days. Damaged goods must be retained for inspection/collection.

Returns

The Company does not operate a returns policy unless the goods are defective:

In circumstances where the Company agrees to accept return of goods, a charge of 25% of the invoice value will be made.

Damage claim form

Machine: **STADIUM CHUTE**

Product code: **VI017S**

Customer name.....

Date of delivery.....

Machine serial number.....

Damage comments.....

.....

.....

.....

.....

Please indicate on the picture where the unit is damaged

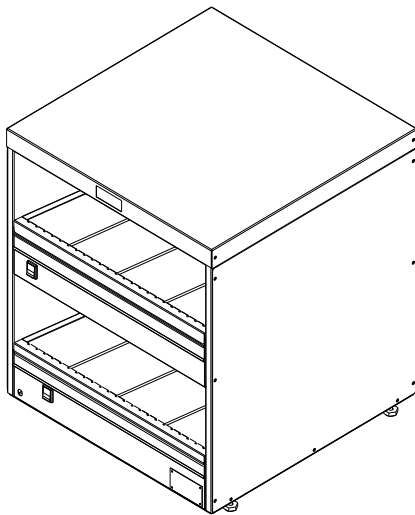

Courier name.....



Please cut this page out and post to **Fast Food Systems**
(The address is on the back of this manual)

Warranty

UNITED KINGDOM AND REPUBLIC OF IRELAND

Excepting where otherwise specified all products are subject to 12 months parts and labour warranty. Goods found defective will be repaired, credited or replaced without charge according to the terms of the Company's standard warranty, provided written notice is given within the guarantee period. In no case will the company be liable for repairs made without it's knowledge or sanction, or for indirect damage, or any consequential loss or expense incurred by purchasers.

Fast Food Systems Ltd, warrants to the original purchaser that the equipment supplied to be free from defective materials or workmanship for a period of 12 (twelve) months.

The following are NOT covered by warranty:

1. Failure or breakdown caused by incorrect installation.
2. Adjustment or calibration of controls - this is a routine maintenance function.
3. Abuse or misuse, including cleaning.
4. Warranty labour is only carried out during normal working hours, calls out of hours may be subject to surcharges.
5. The warranty will commence either on installation or 1 (one) month from date of dispatch - whichever is the sooner.
7. Warranty on spare parts purchased for equipment outside of the warranty period is 3 (three) months from date of sale.
8. Any faulty spare parts replaced under warranty must be returned with 7 days of supply.
9. Warranty is non-transferable.

Fast-Food-Systems Ltd will not be held responsible, financially or otherwise, for any loss of business as a result of equipment breakdown.

MODEL NUMBER.....

ORDER ID/JOB NO.....

MACHINE SERIAL NUMBER.....

DATE OF MANUFACTURE/...../.....

DATE OF DELIVERY...../...../.....

DATE OF COMMISSIONING...../...../.....

	<p>ENGLISH</p> <p>Electrical equipment marked with this symbol may not be disposed of in European public disposal systems after 12 August 2005. In conformity with European local and national regulations (EU Directive 2002/96/EC), European electrical equipment users must now return old or end-of-life equipment to the manufacturer for disposal at no charge to the user.</p> <p>Note: For return for recycling, please contact the equipment manufacturer or supplier for instructions on how to return end-of-life equipment for proper disposal.</p>
---	---

Fast Food Systems Limited
 Manufacturer & Distributor of Catering Equipment

Unit 1 Headley Park 9 Headley Road East

Woodley Reading Berkshire RG5 4SQ

Tel: 0118 944 1100 Fax: 0118 944 0350

Email: service@fast-food-systems.co.uk

Website: www.fast-food-systems.com

ISSUE 08: 12th October 2018